



# Orange Grapple HGB220

Application - Waste handling, scrap handling, material rehandling



## Features and benefits

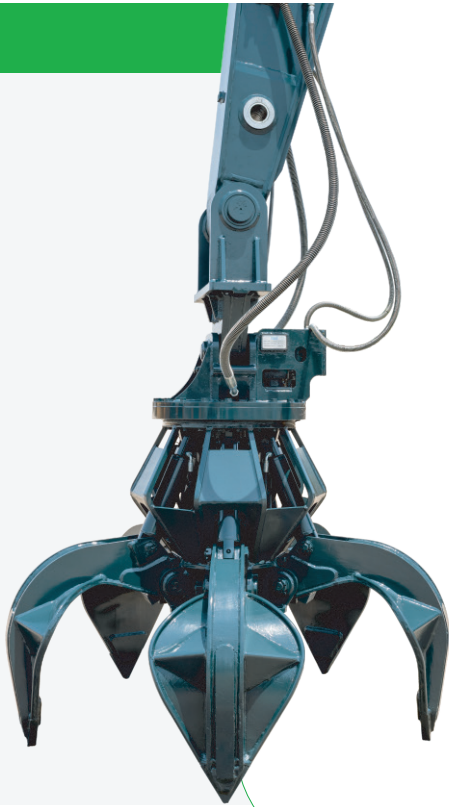

Heavy Duty 5 tins design



360° clock and anti-clock rotation



Perfect solution for scrap handling



Hardox material for reliability & longer life



Full operation control from cabin



Speed control for better productivity

## Technical Specification

| Model                       | Unit | HGB220                             |
|-----------------------------|------|------------------------------------|
| Excavator Weight            | ton  | 20-24T                             |
| Unit Weight                 | kg   | 1300                               |
| Capacity                    | m3   | 0.8                                |
| Max Pressure Cylinder       | bar  | 280                                |
| Max Pressure Rotation       | bar  | 140                                |
| Working Flow Cylinder       | lpm  | 250                                |
| Working Flow (lpm) Rotation | lpm  | 80                                 |
| No of TINES                 | -    | 5                                  |
| Opening Length              | mm   | 1597                               |
| Overall Length              | mm   | 1675                               |
| A                           | mm   | 902                                |
| B                           | mm   | 1178                               |
| C                           | mm   | 1597                               |
| D                           | mm   | 1798                               |
| E                           | mm   | 1470                               |
| F                           | mm   | 1675                               |
| Applicable Model            | -    | <b>SMART</b> 210, 215, 215L, 230LM |

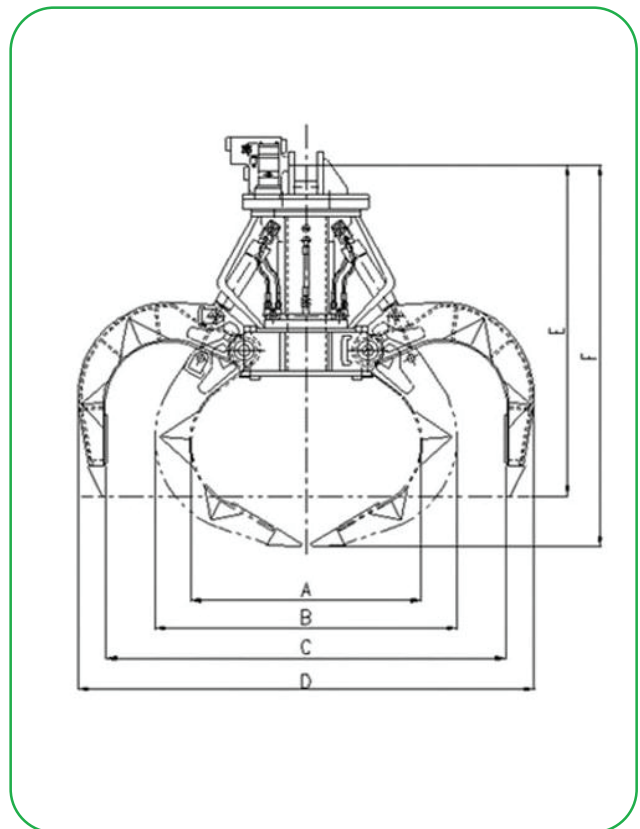

## HD Hyundai Construction Equipment India Pvt. Ltd.

### Factory Location

Plot No. A-2, M.I.D.C. Chakan, Phase II,  
Village: Khalumbre, Taluka: Khed, Dist:Pune-410501  
E mail: parts@hd.com  
Toll Free No.: 1800 209 8600

### Please Contact

Scan the QR code  
with your phone  
camera & visit  
our website

